



SUREGRIP



Custom Made Handling Products
for Abattoirs and Butchers



Manufacturers of Abattoir Equipment
and Spares Since 1977

SUREGRIP

Designed and assembled in Reservoir, Victoria, Suregrip handling products are trusted by industry leading abattoirs and butchers throughout Australia, New Zealand and the Pacific Islands. For over 60 years,

Suregrip products have been hand crafted by the Pitt family. Blacksmith, Peter Pitt has overseen production for the last 40 years.

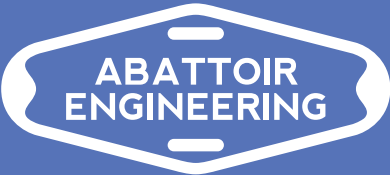

Based in Melbourne, Abattoir Engineering is an active member of the abattoir and rendering industry. In addition to Suregrip products, Abattoir Engineering design and manufacture principal processing and operating equipment and can provide whole plant solutions for abattoirs and rendering plants.

Key Personnel

- Managing Director /** David Pinches
- General Manager /** Charlie Kelaiditis
- Production Manager /** James Collins
- Design Engineer /** Michael Harkness
- Head of Sales /** Jan Nolan
- Production /** Peter Pitt, John Pitt

RSC02 Mutton Slide

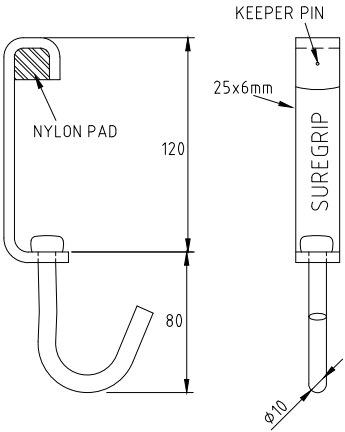

Part No.	RSC02
Body	25mm x 6mm
Hook	10mm Sheared

RSC04 Pig Slide

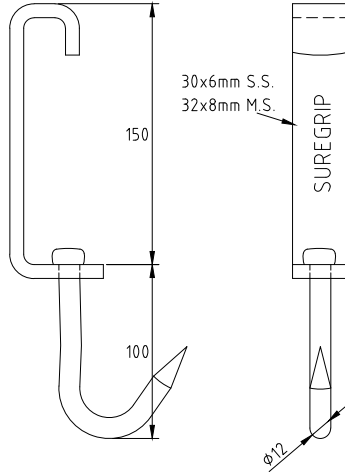

Part No.	RSC04
Body	32mm x 8mm
Hook	12mm Pointed

RSC09 Mutton Shackle

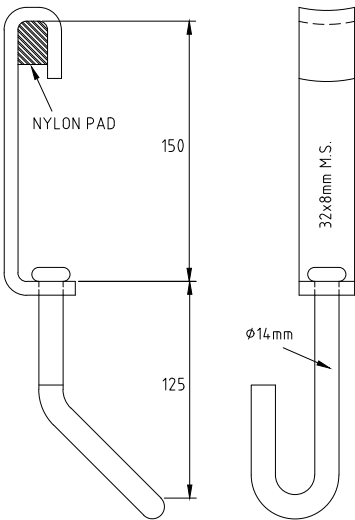

Part No.	RSC09
Body	32mm x 8mm
Hook	14mm Sheared

RSC10 Mutton Shackle Assembly

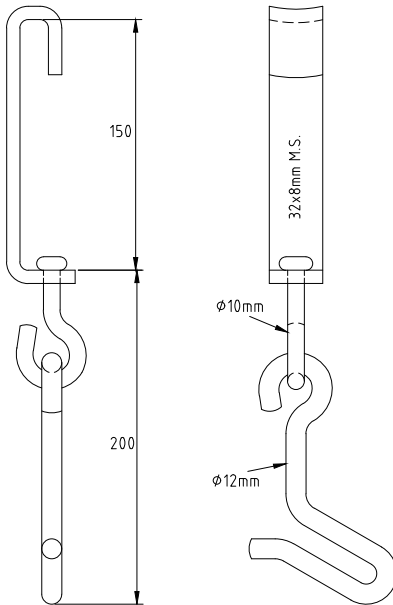

Part No.	RSC10
Body	32mm x 8mm
Hook	12mm Sheared

RSC48 Bleed Strap & Roller

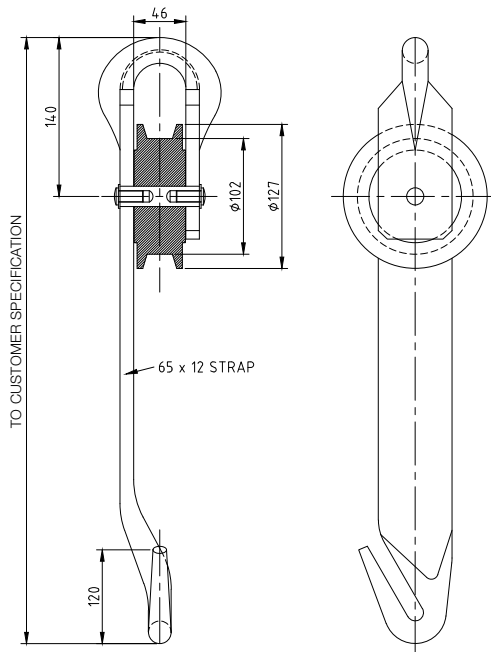

RSC49 Bleed Strap & Roller

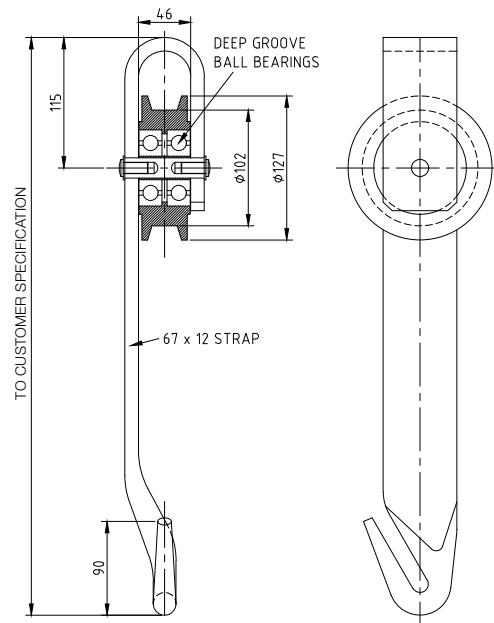

Part No.	RSC48
Body	65mm x 12mm
Hook	120mm Sheared
Load Cap.	1200kg

Part No.	RSC49
Body	67mm x 12mm
Hook	90mm Sheared
Load Cap.	1200kg



RSC60TR Beef Legging Chain with Sling Hook

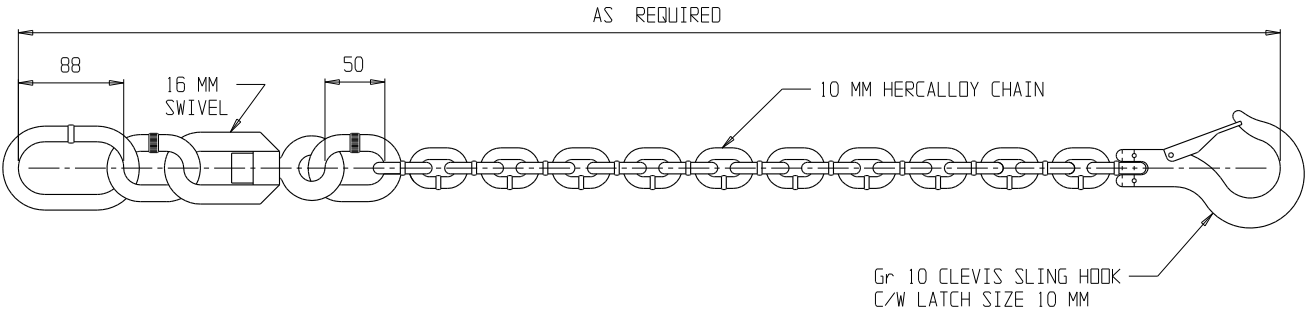

Part No.	RSC60TR	Hook	Sling Hook w/ Latch
Length	Customer Specified	Load Cap.	1500kg

RSC60/R Beef Legging Chain with Oblong Link

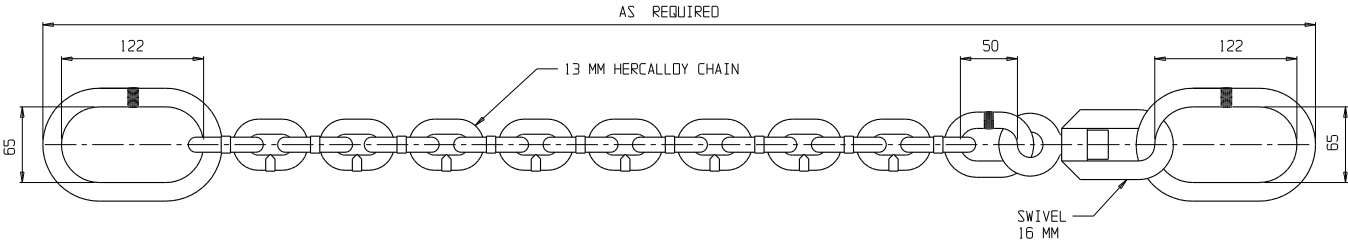

Part No.	RSC60/R	Hook	Oblong Link
Length	Customer Specified	Load Cap.	1500kg



Note: All Slides, Shackles, Bleed Rollers, Legging Chains and Dressing Rollers can be designed and manufactured to individual customer specifications.

RSC53 Dressing Roller Assembly

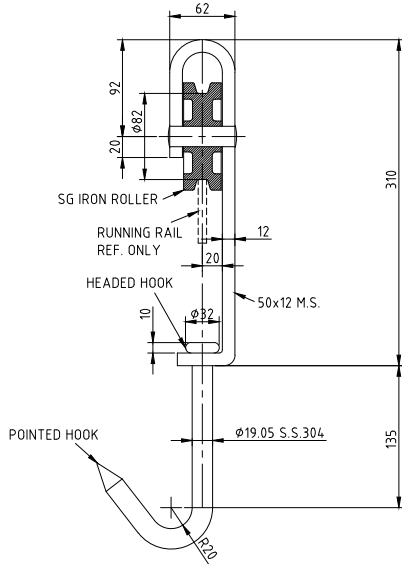

Part No.	RSC53
Body	50mm x 12mm
Hook	19.05mm Pointed

RSC54 Dressing Roller

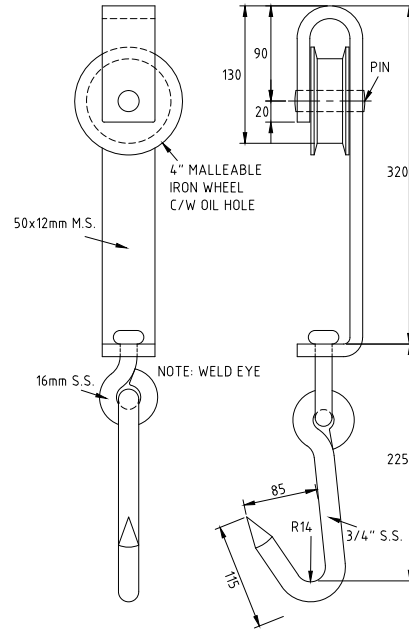

Part No.	RSC54
Body	50mm x 12mm
Hook	19.05mm Pointed

Aluminium Skid

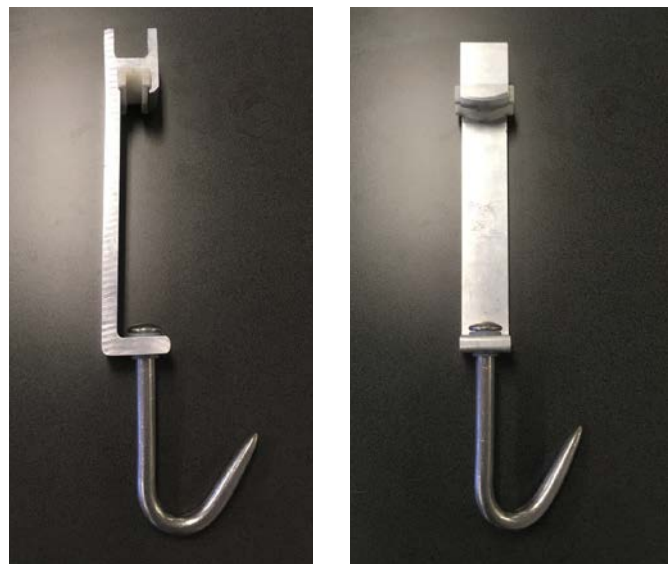
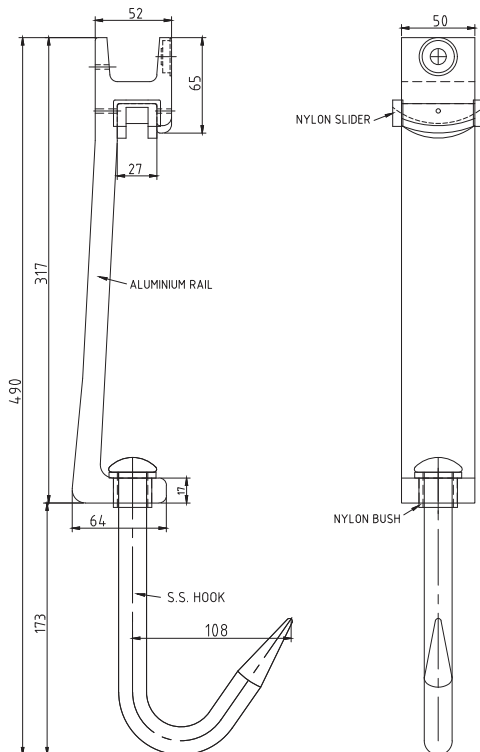

Part No.	ALUSKID
Body	50mm x 17mm
Hook	19.05mm Pointed
Includes	Nylon Bridge and Bush

Additional Abattoir Equipment

Batch Cookers	Used in the rendering process to condition, sterilize, hydrolyze and dry raw materials. Batch Cookers can be used to render red meat, white meat, feathers, blood or a mixture of by-products.
MK2 Prebreakers	Specifically designed for size reduction of animal carcasses, bones, offal and related materials.
Hammer Mills	Used in the reduction of particle size in meat meal. Available in a range of sizes.
Hasher Washers	Suitable for cutting and washing Soft Offal, Gut, Paunches and Bibles.
Washer Trommels	Designed to wash and sieve material via a rotating perforated barrel.
Tripe Washers	Used to wash and peel (whiten) the internal part of the beef and sheep tripes.
Rail Switches	Used to house and transport Abattoir handling equipment. Can be built to plant specification.
Mincers	Designed to mix and mince meat, and a variety of other products cleanly and efficiently.
Mill Screens	Original and replacement mill screens for hammer mills – used predominantly in the rendering industry.
Holeplates, Knives and Precutters	Suitable for a full range of mincing needs and made to fit all mincers and grinders. New items can be manufactured to customer specification.
Small Stock Stunners	Designed for the humane dispatch of animal livestock with a weight capacity up to 70kg, suitable for sheep, pigs, calves and goats.
Related Equipment	Including beef hoists, auto lander hooks, crucifix blocks and trip fingers

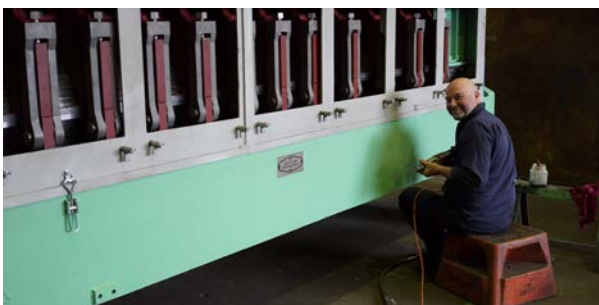

Maintenance and Servicing:

Abattoir Engineering provide servicing on all abattoir equipment, including grinding and sharpening for consumable items such as mincer holeplates and knives and can provide assessments on second hand equipment and ongoing plant maintenance services.



Testing and Certification:

All Suregrip Chains and Rollers come certified to Australian Lifting Equipment Standards and all existing handling equipment can be inspected, tested, re-certified and modified (if required) on-site in Reservoir, Victoria.

Legging Chains: AS3775-2014 Australian Standard Chains/Slings

Bleed Rollers: AS4991-2004 Australian Standard Lifting Devices Design



Abattoir Engineering

Address

21 Malua Street
Reservoir VIC 3073

PO BOX 120
Reservoir VIC 3073

Phone 03 9460 2466

Fax 03 9462 1102

www.abattoireng.com.au
abeng@pinches.com.au

A division of Pinches Group